

# FORMULA

## INTERCHANGEABLE SYSTEM



UNILOCK COLLET-CHUCK FOR C.N.C. LATHES

01

**UNILOCK**  
clamping solutions

THE ACCURACY OF MECHANICS,  
THE HUMAN TOUCH.



# FORMULA

## INTERCHANGEABLE SYSTEM



**FORMULA** - Interchangeable System - offers the capability to vary the clamping system of the part with the one most suited to the type of work to be carried out. The system consists of a fixed BASE interfaced to the lathe, with ASA or ISO standards, on which is possible to "formulate" three different clamping systems:

- 1) **FORMULA PUSH - Dead-length collet system**  
Base + Cylinder + Bush + Collet + Clamping nut
- 2) **FORMULA PULL - Pull System**  
Base + Cylinder + Bush + Clamping nut + Collet
- 3) **FORMULA IN - Pull System**  
Base + Cylinder + Bush + Clamping nut + Collet



## ADVANTAGES

- Adaptability and flexibility to specific needs for any machining
- Less downtime
- Quick change of the clamping system
- High clamping force
- Easy in assembly and disassembly

# FORMULA

## INTERCHARGEABLE SYSTEM

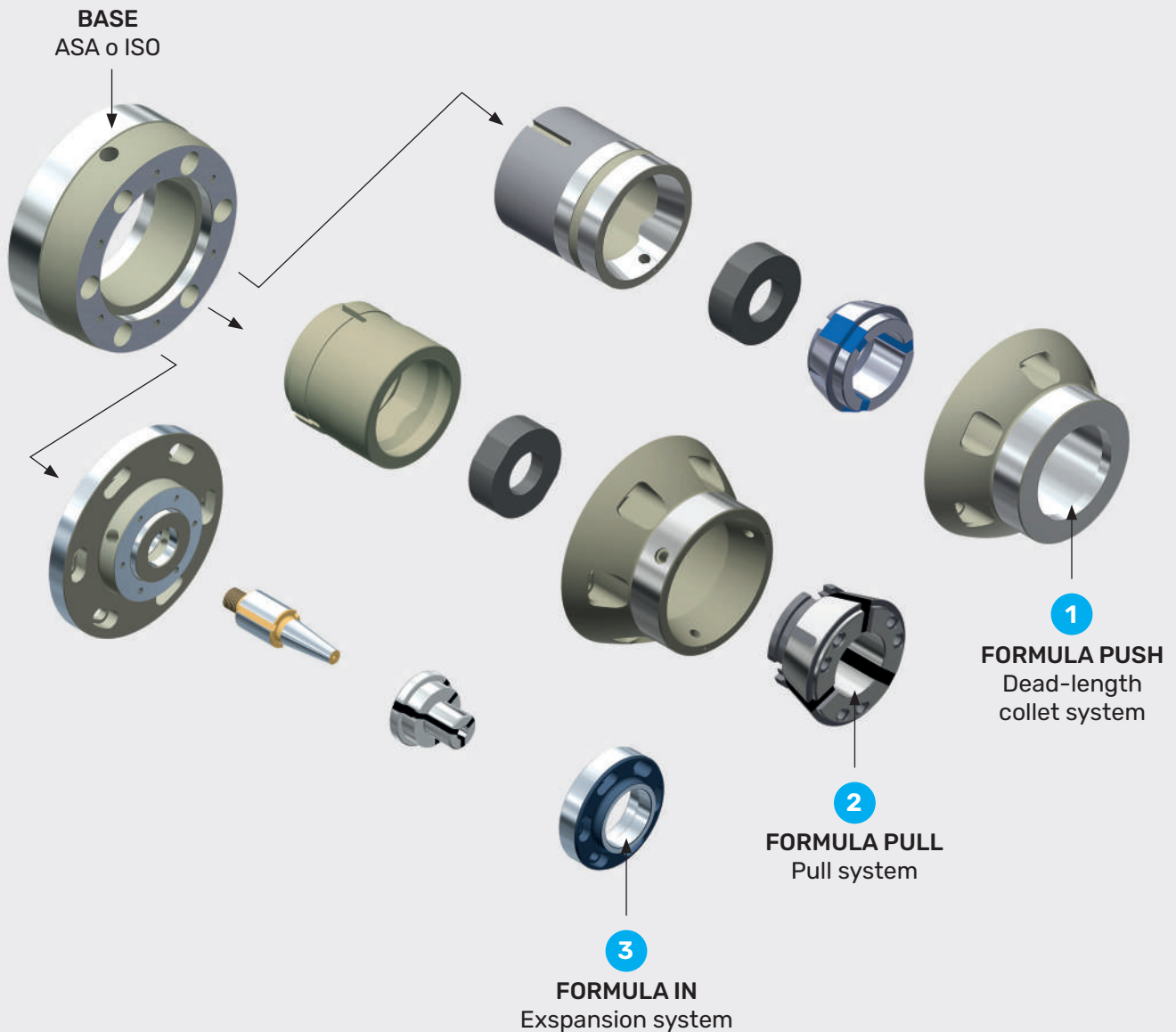

## FEATURES

**FORMULA PUSH** The collet remains stationary, coupled to the spindle clamping nut while the rear tapered cylinder advances for tightening.

**FORMULA PULL** The collet couples directly with the spindle cone.

[www.unilock.it](http://www.unilock.it)

**FORMULA IN** The collet remains stationary and the pin must be pushed inside the conical shape to make the collet expand radially.



# FORMULA PUSH

## DEAD-LENGTH COLLET SYSTEM



In **FORMULA PUSH** the collet remains stationary coupled to the spindle clamping nut while the rear tapered cylinder advances for tightening. The collet is changed quickly by simply loosening the front clamping nut. The collet closes parallel to the bar without interfering on its position.

### Main uses

Applied to the lathe counter-spindle, tighten the piece without loading the spindle axis and do not trigger the alarm of the C.N.C.

Suitable for bar and secondary machining, with excellent tightening repeatability.

All **UNILÖCK SMS** collet-chucks are **COMPATIBLE** with **FB, BA** and **DIN 6343** collets.

## ADVANTAGES

- Minimum clearance
- Quick change clamping nut
- Bar clamping with stationary collet
- Does not mark the surface of the piece
- Fewer machine downtimes
- Machining tolerance lower than DIN tables
- Range of machining: -1.0 mm
- Clamping of raw pieces (rolled, forged, castings)

# FORMULA PUSH

## DEAD-LENGTH COLLET SYSTEM

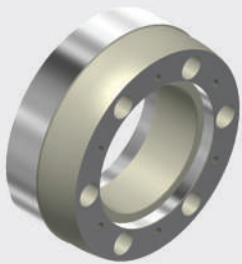
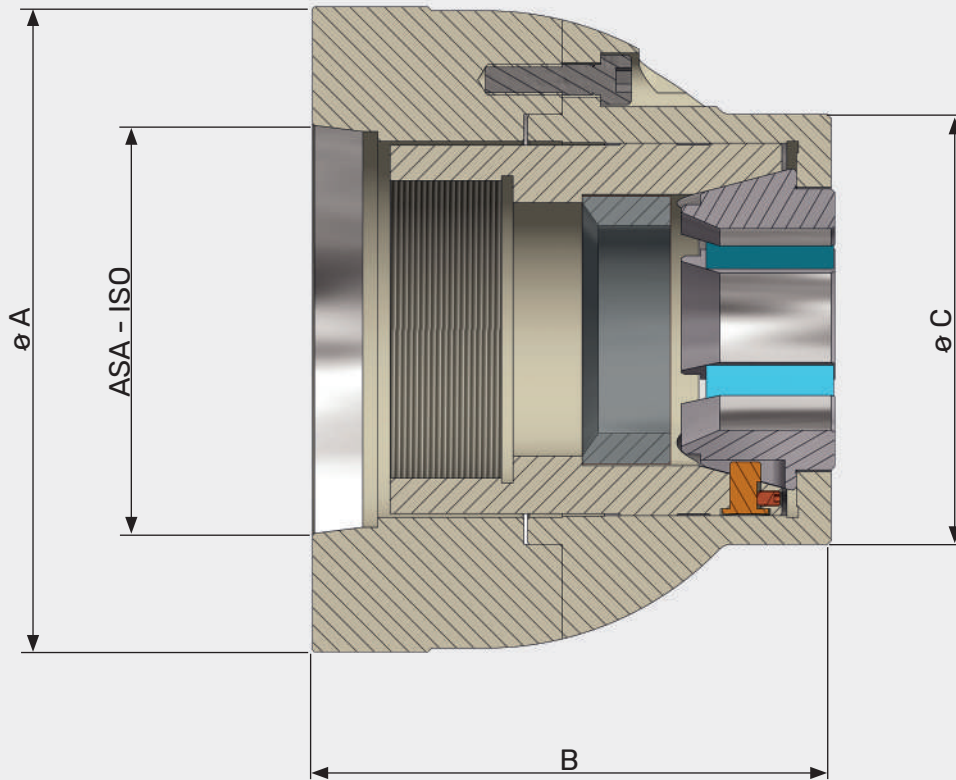

Base ASA or ISO

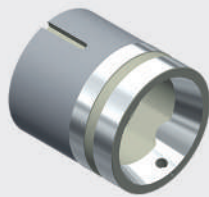

Master sleeve





Bush



Collet



Quick change clamping nut

ITEM N.	ASA	ISO	A	B	C		
<b>SMS 45</b>	5	115 - 120	$\varnothing$ 135	127	$\varnothing$ 88	$\varnothing$ 45	ch 39
<b>SMS 56</b>	5 - 6	120 - 170	$\varnothing$ 168	135	$\varnothing$ 112	$\varnothing$ 56	ch 48
<b>SMS 65</b>	5 - 6	120 - 170	$\varnothing$ 168	135	$\varnothing$ 112	$\varnothing$ 65	ch 56
<b>SMS 80</b>	6 - 8	170	$\varnothing$ 208	145	$\varnothing$ 132	$\varnothing$ 80	ch 69
<b>SMS 95</b>	8 - 11	-	$\varnothing$ 198	164	$\varnothing$ 178	$\varnothing$ 95	ch 82



# FORMULA PULL

## PULLING FORCE SYSTEM



In the pull system **FORMULA PULL** the collet couples directly with the spindle cone.

### Main uses

Applied to the lathe main spindle it is suitable for bar machining. Moreover, thanks to the construction flexibility of the system, it allows easy specific solutions (drawn bars, rectified items, rolled items, pipes).

The rubber coating of the collets does not allow shavings to pass inside the spindle.

### Quick change collet

The system allows a fast front removal of the collet. In this way, replacement or disassembly collet cleaning operations result easier and quicker, without dead times.

All **UNILÖCK SMH** collet-chucks are **COMPATIBLE** with original **HAINBUCH** collets

## ADVANTAGES

- Strong clamping strength
- Machining tolerance lower than DIN tables
- Minimum weight and small clearance
- Range of machining: -1.0 mm
- Strength for a noteworthy decrease of the vibrations of the piece machined
- Clamping of raw pieces (rolled, forged, cast elements)
- Quick change collet

# FORMULA PULL

## PULLING FORCE SYSTEM

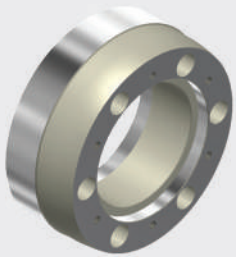
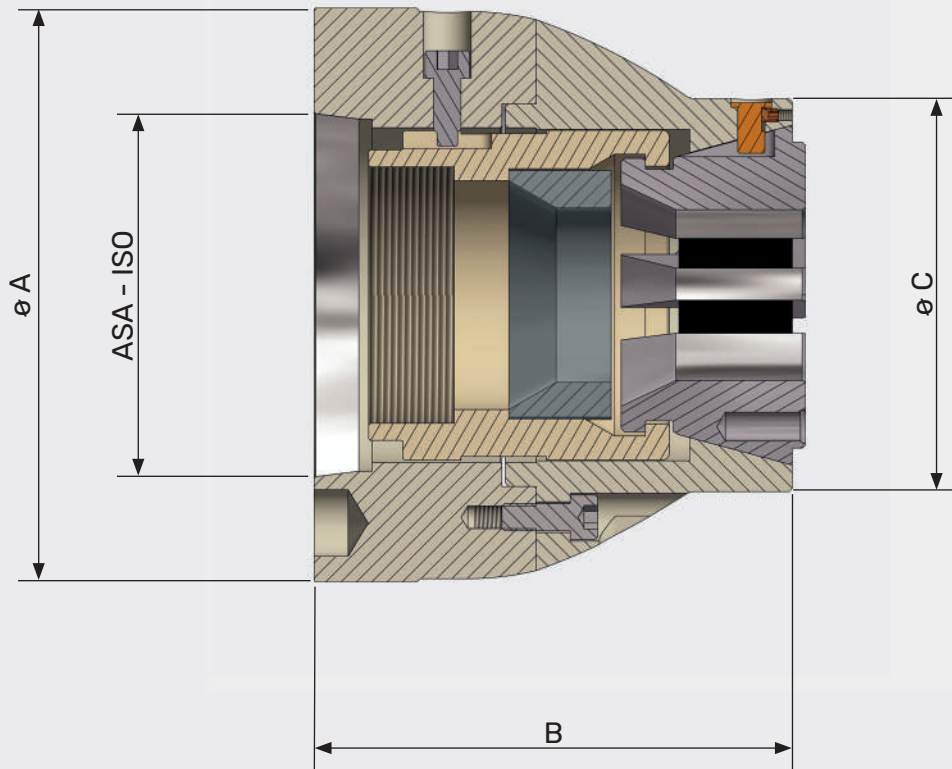

Base ASA or ISO

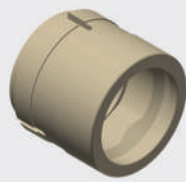

Master sleeve



Bush



Quick change clamping nut



Collet

ITEM N.	ASA	ISO	A	B	C	●	⬡
<b>SMH 42</b>	5	115 - 120	$\varnothing$ 135	127	$\varnothing$ 95	$\varnothing$ 42	ch 38
<b>SMH 52</b>	5	115 - 120	$\varnothing$ 135	127	$\varnothing$ 95	$\varnothing$ 52	ch 45
<b>SMH 65</b>	5 - 6	120 - 170	$\varnothing$ 168	140	$\varnothing$ 115	$\varnothing$ 65	ch 56
<b>SMH 80</b>	6 - 8	140 - 170	$\varnothing$ 208	145	$\varnothing$ 142	$\varnothing$ 80	ch 68
<b>SMH 100</b>	8 - 11	170	$\varnothing$ 228	162	$\varnothing$ 168	$\varnothing$ 100	ch 86



# FORMULA IN EXPANSION SYSTEM



In the expansion system **FORMULA IN** the collet remains stationary. The pin is pushed inside the clamping collet to make expand radially. Strong clamping force, suitable for heavy duty machining on raw pieces. Great concentricity accuracy.

## Main uses

Secondary machining of bored piece to complete the external machining on the counter-spindle.

Applied to the main spindle, it blocks the raw pieces (castings) and bored pieces internally.

Allows to load the piece with automatic systems (robots).

All **UNILÖCK SMH** collet-chucks are **COMPATIBLE** with original **HAINBUCH** collets

## ADVANTAGES

- Minimum clearance
- Piece clamping with stationary collet radial clamping without pull-back effect
- Does not mark the surface of the piece
- Fewer machine downtimes
- High repeatability accuracy
- Machining tolerance lower than DIN tables
- Range of machining: + 0.5 mm / - 0.5 mm
- Clamping of raw pieces (rolled, forged, castings)



# FORMULA IN EXPANSION SYSTEM

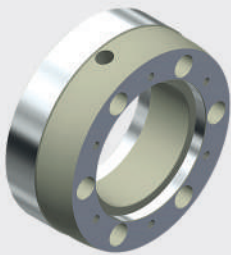
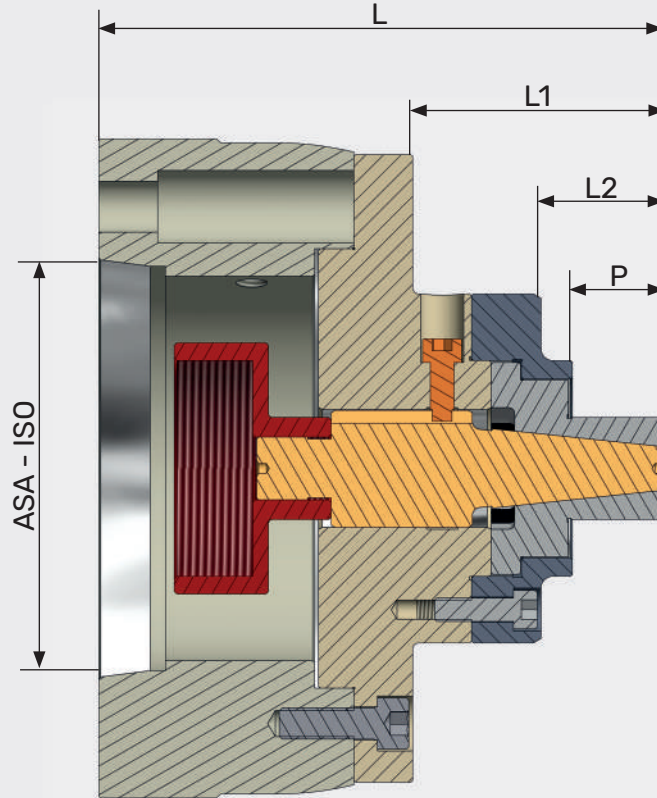

Base ASA or ISO



Collect-chuck



Pin



Collet



Quick change  
Workpiece-stop nut

ITEM N.	ASA	ISO	L	L1	L2	P
<a href="#">SME 15 - 19</a>	5 - 6 - 8	120 - 170	125	55	22	15
<a href="#">SME 20 - 25</a>	5 - 6 - 8	120 - 170	135	65	32	25
<a href="#">SME 26 - 45</a>	5 - 6 - 8	120 - 170	135	65	32	25
<a href="#">SME 40 - 60</a>	6 - 8	170	175	90	52	45
<a href="#">SME 60 - 80</a>	6 - 8	170	190	105	67	60
<a href="#">SME 80 - 100</a>	6 - 8	170	223	134	86	70
<a href="#">SME 100 - 160</a>	6 - 8 - 11	170	223	134	-	90
<a href="#">SME 160 - 220</a>	8 - 11	-	223	134	-	90



# FORMULA INTERCHANGEABLE SYSTEM

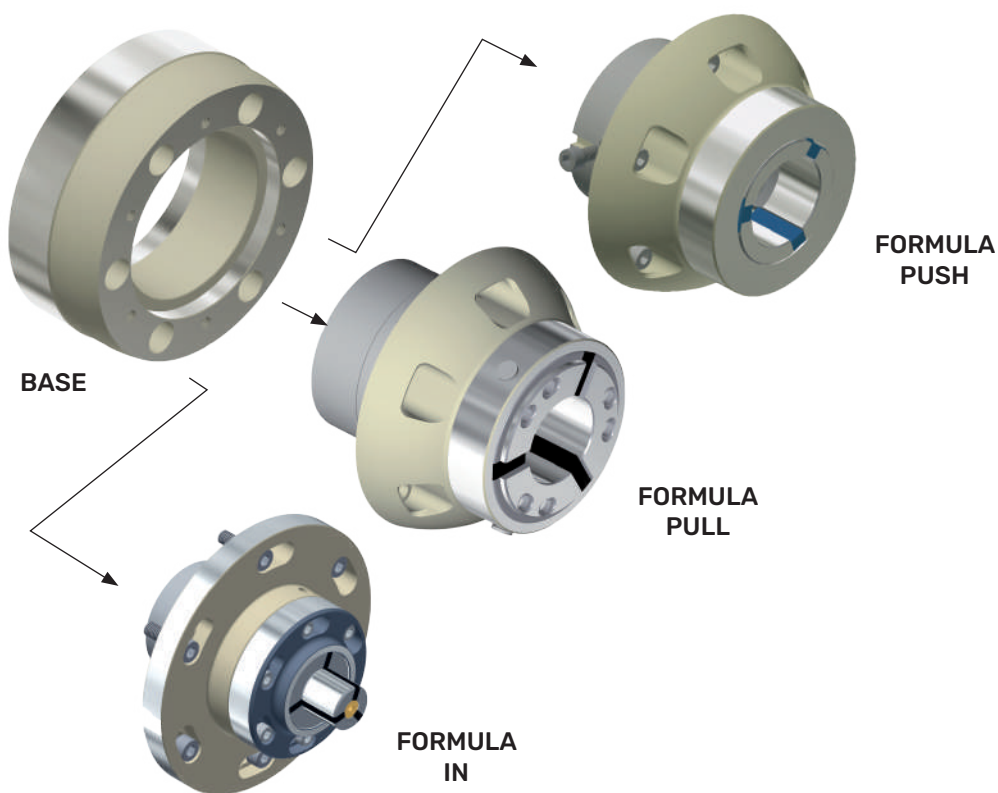

	BASE	FORMULA PUSH	FORMULA PULL	FORMULA IN
<b>FORMULA 45</b>	ASO/ISO	SMS 45 SMS 56	SMH 52	SME 15 - 19 SME 20 - 25 SME 26 - 45 SME 40 - 60 SME 60 - 80
<b>FORMULA 65</b>	ASO/ISO	SMS 65 SMS 75	SMH 65	SME 15 - 19 SME 20 - 25 SME 26 - 45 SME 40 - 60 SME 60 - 80 SME 80 - 100 SME 100 - 120
<b>FORMULA 80</b>	ASO/ISO	SMS 80	SMH 80	SME 15 - 19 SME 20 - 25 SME 26 - 45 SME 40 - 60 SME 60 - 80 SME 80 - 100 SME 100 - 120 SME 120 - 140 SME 140 - 190

# UNILÖCK

clamping solutions

**THE ACCURACY OF MECHANICS,  
THE HUMAN TOUCH.**



[www.unilock.it](http://www.unilock.it)

clamping solutions

2022 edition



w w w . u n i l o c k . i t

**UNILÖCK**  
clamping solutions

**UNILOCK SAS**

📍 Viale Edison, 56  
20090 Trezzano S/N (MI) • Italy  
☎ (+39) 02 48401499  
✉ info@unilock.it  
🌐 www.unilock.it